

REVISIONS

REV.	DESCRIPTION	DATE	APPROVED

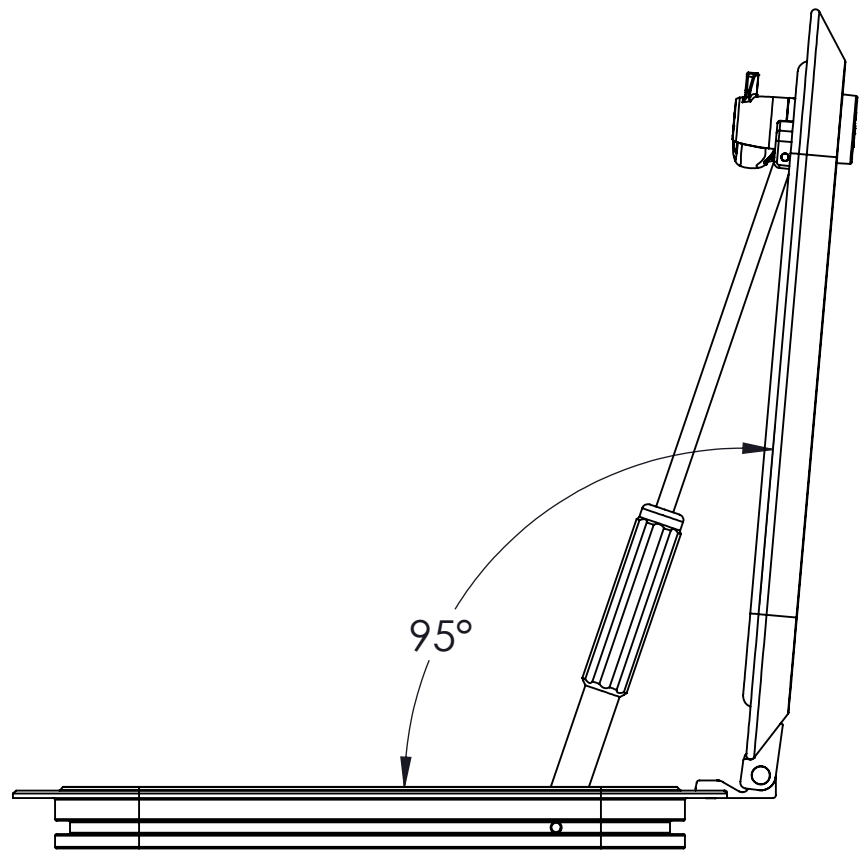

4X R3.031 LID

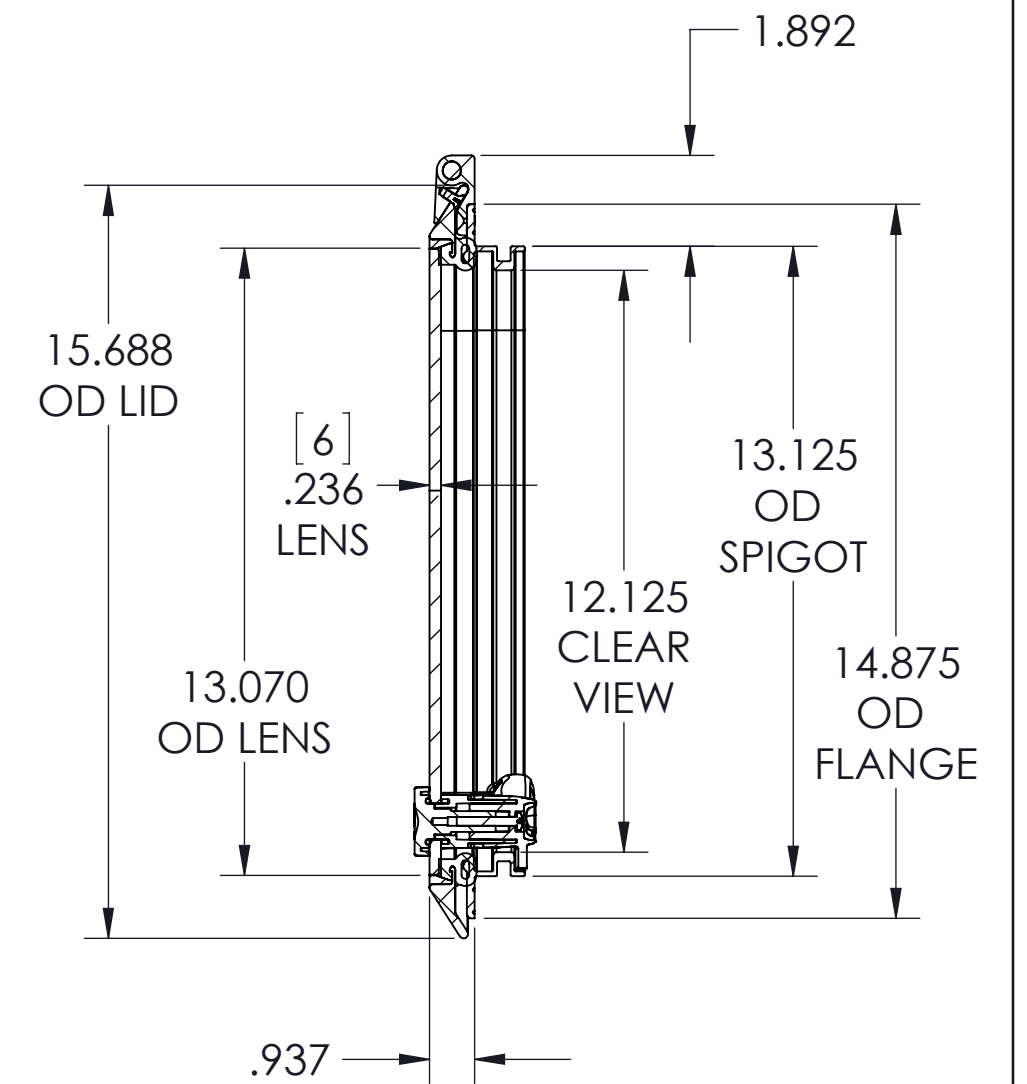
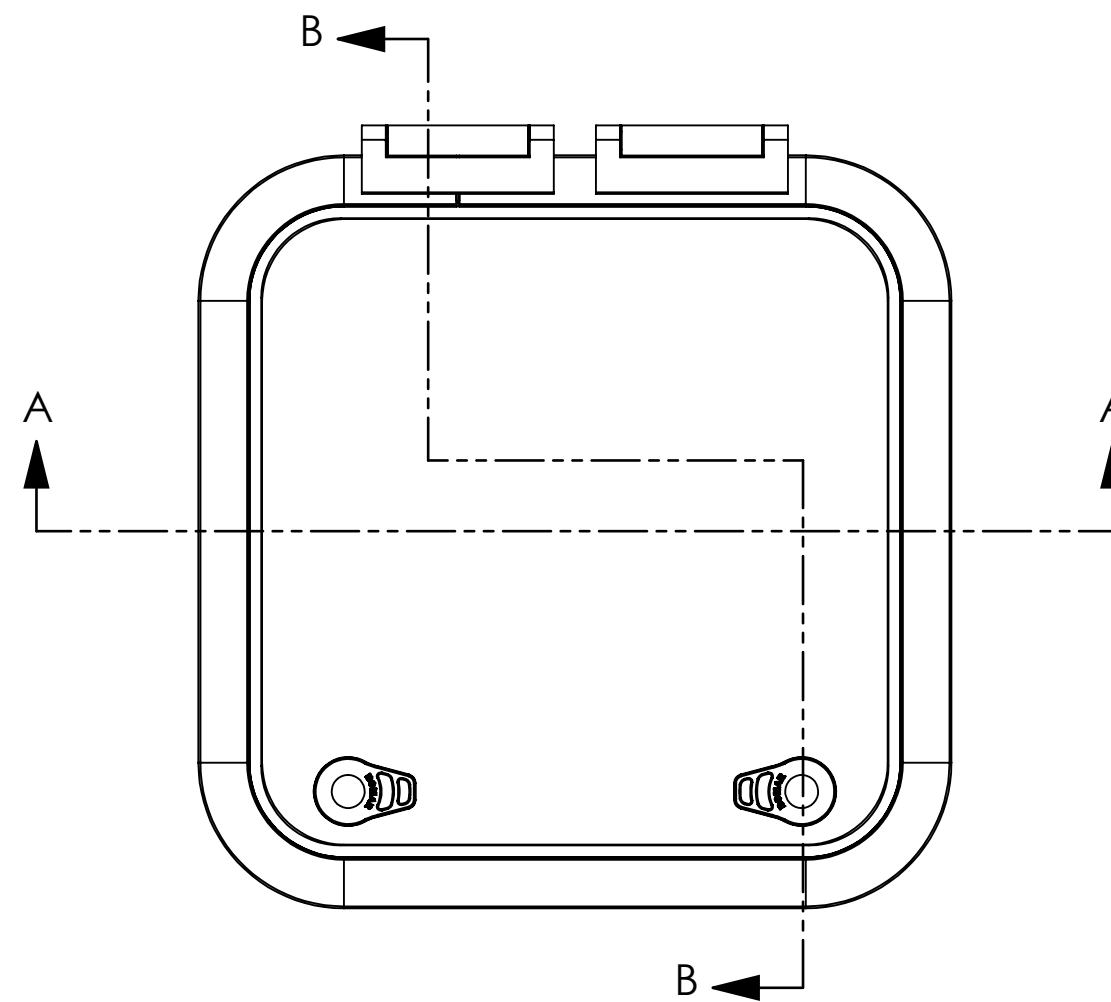
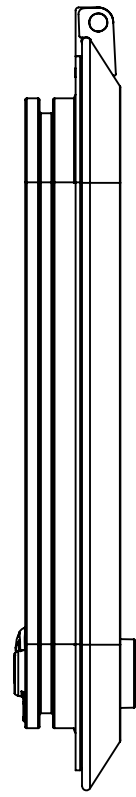
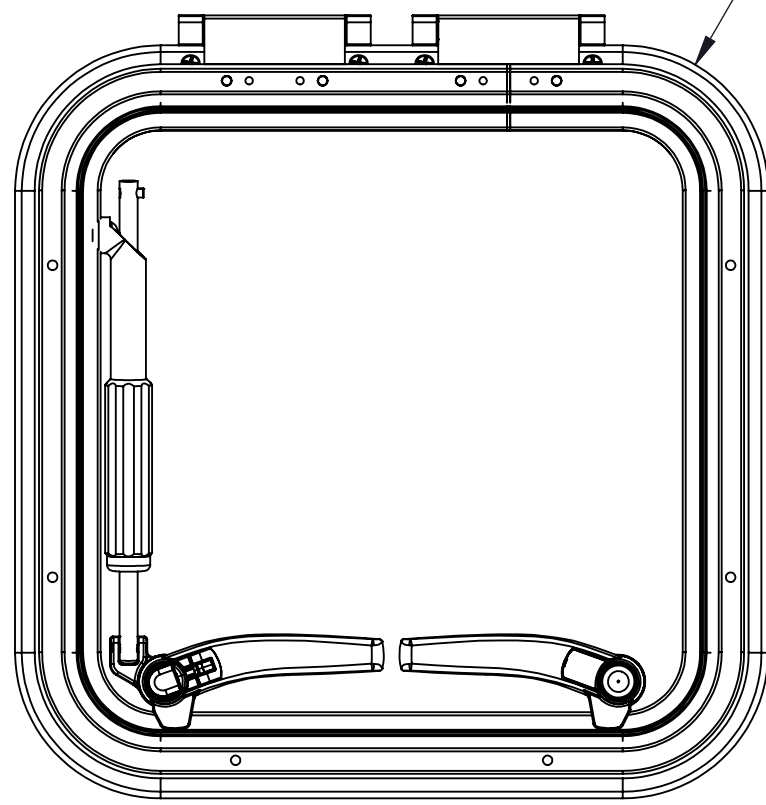

SECTION B-B

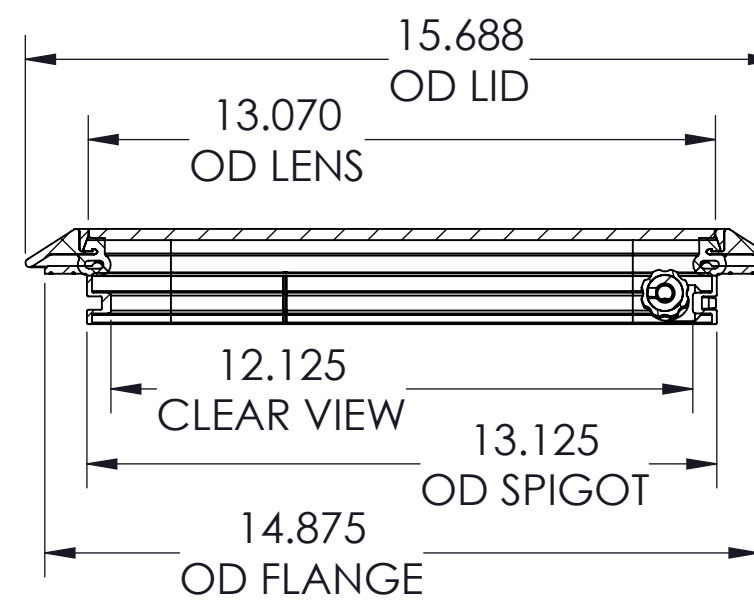

SECTION A-A

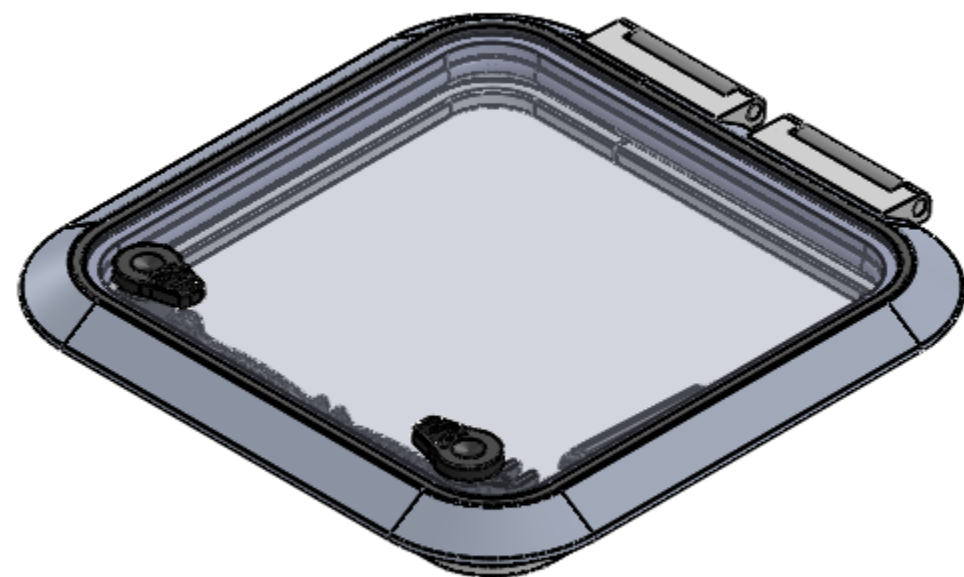

NOTE:
SUGGESTED CUTOUT = 13-1/4 X 13-1/4
CUTOUT RADIUS = 1-11/16 RADIUS

<small>THIS DRAWING IS THE PROPERTY OF POMPANETTE, LLC. CHARLESTOWN, N.H. ALL RIGHTS ARE RESERVED. THIS DRAWING AND INFORMATION MAY NOT BE COPIED OR DISCLOSED TO OTHERS WITHOUT WRITTEN PERMISSION OF POMPANETTE, LLC.</small>				<small>DIV. OF Pompanette INC. 73 SOUTHWEST ST. PO BOX 1200 CHARLESTOWN, N.H. 03803 PH: (603) 826 5791 FAX: (603) 826 3074</small>	
TOLS. ±1/64	TITLE LOW PRO HATCH ASSEMBLY WITH 'A' TOP				
FRACT. .XXX = ±.005	MATL. SEE BOM		DRAWN BY JPERRY		1 OF 1
DEC. XX = ±.01	SCALE 1:4	SIZE ©	DATE 1/2/13	PART NO. N1065-10A	